

Basic Instructions only!
 For more detailed product information, refer to the
GearBoss High-Density Storage System Owner's Manual 240A099.

⚠ CAUTION

Make sure anyone assembling, installing or using this product has read and understands these instructions.

⚠ CAUTION

Failure to comply with Warnings and Cautions in this document or on the equipment can result in damage to property or serious injury.

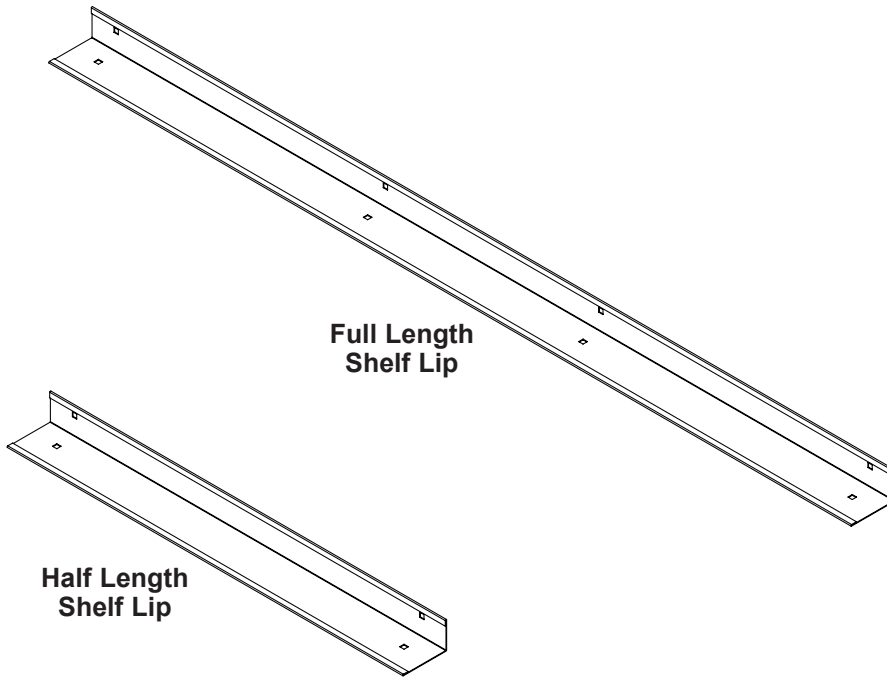

Contents

Full Length Shelf Lip Installation 2	Replacement Parts Lists 4
Half Length Shelf Lip Installation 3	



Visit the GearBoss High-Density Storage System web page at gearboss.com for more information.

Note: Please read and understand these instructions before proceeding.
Note: If you need additional information, contact Wenger Corporation using the information below.

Full Length Shelf Lip Installation

NOTICE

The full length shelf lip is designed to be used with the full length wire shelf accessory. The shelf lip can be installed with either the tall or short edge up.

1. Place the shelf lip centered at the desired location on the wire shelf.

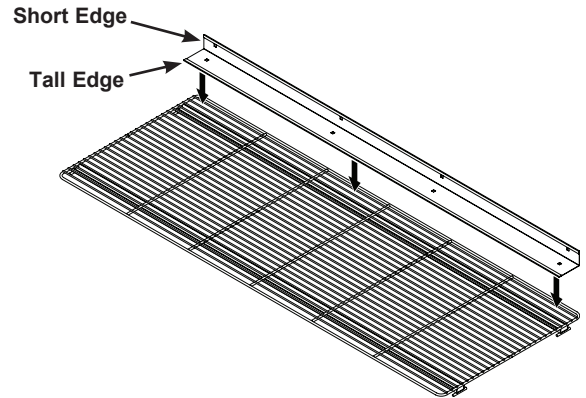

2. Insert the carriage bolt through a square hole in the shelf lip and secure with a wing nut.
3. Repeat for the other end of the shelf followed by the middle two mounting locations.

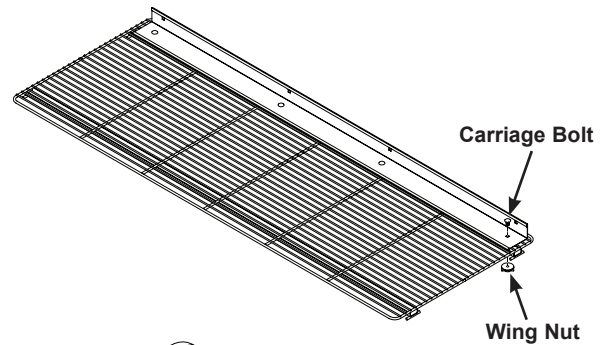

4. The shelf lip accessory kit includes two shelf lips and mounting hardware for both. Install the other shelf lip repeating steps 1 - 4 on the other side of the cart.

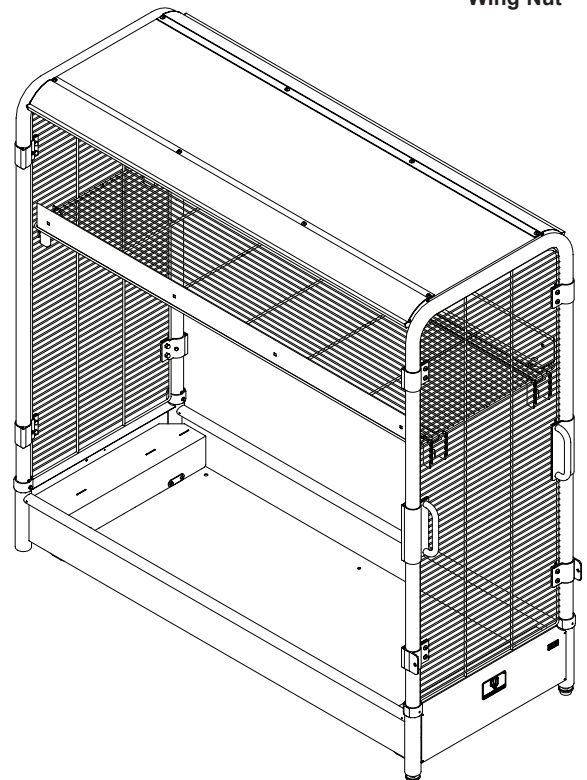

Half Length Shelf Lip Installation

NOTICE

The half length shelf lip is designed to be used with the half length wire shelf accessory along with the cart divider accessory.

The half shelf lip can be installed with either the tall or short edge up.

1. Place the shelf lip centered at the desired location on the wire shelf.

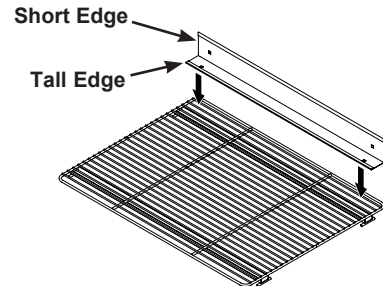

2. Insert the carriage bolt through a square hole in the shelf lip and secure with a wing nut.
3. Repeat for the other end of the shelf.

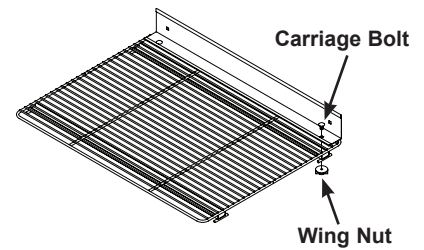

4. The Shelf lip accessory kit includes two shelf lips and mounting hardware for both. Install the other shelf lip repeating steps 1 - 4 on the other side of the cart.

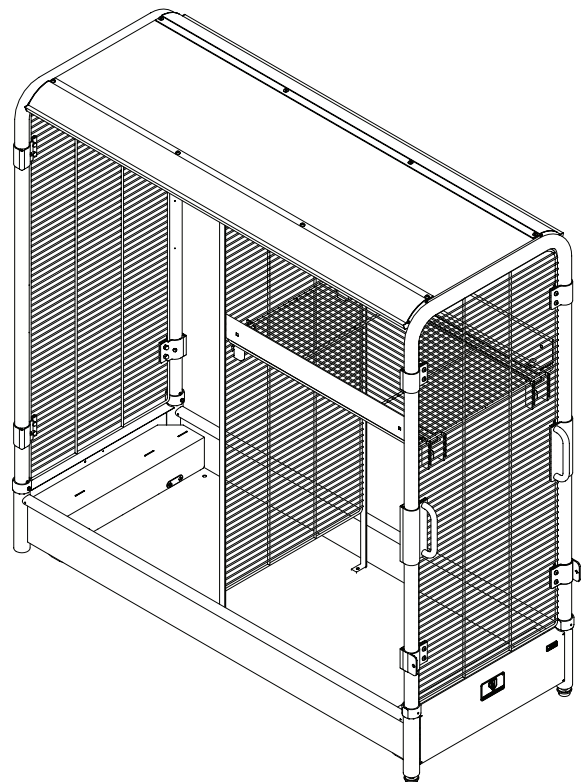

Replacement Parts Lists

Full Length Shelf Lip Accessory

Item	Qty	Description
1	1	Full Length Shelf Lip
2	4	Carriage Bolt
3	4	Wing Nut

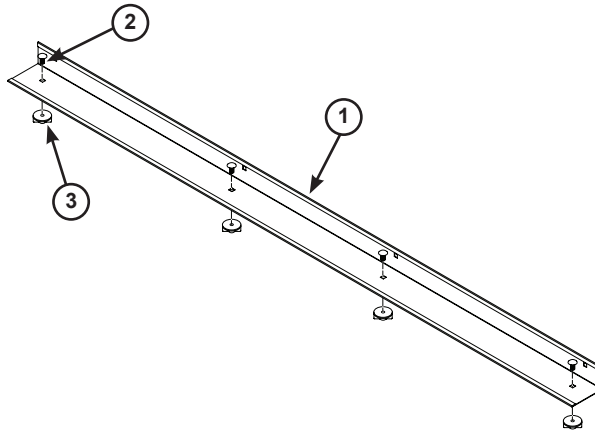

Half Length Shelf Lip Accessory

Item	Qty	Description
1	1	Half Length Shelf Lip
2	2	Carriage Bolt
3	2	Wing Nut

